

MFJ

IntelliTuner™ *Automatic Antenna Tuner*

Model MFJ-994



INSTRUCTION MANUAL

CAUTION: Read All Instructions Before Operating Equipment

MFJ ENTERPRISES, INC.

300 Industrial Park Road
Starkville, MS 39759 USA
Tel: 662-323-5869 Fax: 662-323-6551

Contents

THE BASICS

Introduction.....	1
Features.....	2
Specifications.....	2
Fast Start.....	3
Front Panel.....	4
SWR/Wattmeter.....	4
C-UP and C-DN Buttons.....	4
L-UP and L-DN Buttons.....	4
AUTO Button.....	4
TUNE Button.....	5
POWER Button.....	5
Back Panel.....	6
Power.....	6
Remote Port.....	6
Radio Interface.....	6
Transmitter.....	7
Ground.....	7
Wire.....	7
Antenna.....	7
Installation.....	8
SWR/Wattmeter.....	8

SETUP

Target SWR.....	9
Auto Tune SWR.....	9
Meter Range.....	10

OPERATION

Manual Tuning.....	10
Component Limit.....	11
Antenna Memory.....	11
Tuner Status Indicators.....	12
Grounding Hints.....	13
Antenna System Hints.....	13
Location.....	13
Matching Problems.....	13

APPENDICES

Firmware Version Number	15
Resetting the Tuner	15
Factory Defaults	15
Delete Antenna Memory	16
Total Reset	16
Self Test	16
Power Down Circuit Test	17
Relay Test	18
Wattmeter Calibration	18
SWR Bridge Calibration	19
Frequency Counter Calibration	20
In Case of Difficulty	20
Technical Assistance	21
List of Accessories	21
Circuit Block Diagram	22

FIGURES

Figure 1. Installation Block Diagram	3
Figure 2. MFJ-994 Front Panel	4
Figure 3. Button Action	5
Figure 4. MFJ-994 Back Panel	6
Figure 5. Alinco Interface Cable	7
Figure 6. Icom Interface Cable	7
Figure 7. SWR/Wattmeter	8
Figure 8. Power-On Operations	15
Figure 9. MFJ-994 Circuit Block Diagram	22

TABLES

Table 1. Antenna Memory Resolution	11
Table 2. Meter Needle Codes	12
Table 3. Failure Messages	17

The Basics

Introduction

The MFJ-994 IntelliTuner™ let you rapidly tune antennas automatically: unbalanced or single-wire (or balanced, with an external balun).

MFJ's exclusive InstantRecall™, IntelliTune™ and AdaptiveSearch™ algorithms give you fast automatic tuning with more than 1000 non-volatile memories.

The tuner includes a highly efficient switching L-network with wide matching capability, 1.8 to 30 MHz coverage, cross-needle power meters, a port for an accessory remote control, a radio interface port, and heavy-duty 16 amp/1000 volt relays. It is rated at 600 watts PEP SSB and 300 watts CW.

192 values of capacitance and 192 values of inductance are available. With the inductance switched between the input and output side, this provides a total of 73,728 L/C tuning combinations. The nominal tuning ranges are 0 to 2950 pF and 0 to 17 μ H.

All MFJ IntelliTuners™ learn and remember. When you transmit, they automatically adjust for minimum SWR and remember the frequency and tuner settings, safely stored in non-volatile memory. The next time you operate on that frequency (or close to it), these tuner settings are instantly restored and you're ready to operate in milliseconds. The tuner can learn and remember more than a thousand frequencies and tuner settings.

When you key your transmitter, MFJ's InstantRecall™ checks its memory to see if you have operated that frequency before. If so, tuning is instantaneous and you're ready to operate. If not, MFJ's IntelliTune™ algorithm (based on MFJ's famous SWR Analyzer technology) kicks in. It measures the complex impedance of your antenna. Next, it calculates the components it needs and instantly snaps them in. Finally, it fine-tunes to minimize SWR, and you're ready to operate – all in a fraction of a second.

If the antenna impedance is not within the tuner's measurement range, MFJ's AdaptiveSearch™ algorithm goes into action. Frequency is measured and relevant component values are determined. Only those values are searched for fast tuning. If it still cannot find a match, the search is performed again using a different search pattern.

The target SWR can be set at 1.5 or 2.0. The minimum power to tune is approximately ten watts. You can manually tune where you can't transmit (for listening out of ham bands).

The optional MFJ-993RC Remote Control provides most tuner controls, allowing convenient remote locating of the tuner itself.

All MFJ's IntelliTuners™ support radio tuner interfaces that are compatible with Icom AH-3 and AH-4 tuners and the Alinco EDX-2 tuner. Optional interface cables MFJ-5124A (for Alinco) and MFJ-5124I (for Icom) are available from MFJ Enterprises, Inc. Interface cables for compatible Kenwood and Yaesu radios will be available in the future.

The tuners enter a "sleep" mode when idle and when no transmit signal is present, turning off the microprocessor clock to avoid the generation of spurious signals.

Features

- Automatically matches antennas from 12 to 800 ohms impedance
- Handles 600 watts PEP SSB/300 watts CW
- Tune in less than 15 seconds, usually less than 5 seconds
- Over 1000 non-volatile memories for tuner settings
- Highly efficient switching L-network matching circuit
- 1.8 to 30 MHz continuous frequency coverage
- Selectable target SWR 1.5 or 2.0
- Selectable SWR threshold 0.5, 1.0 or 1.5
- Lighted cross-needle SWR/wattmeter with high, low and auto range options
- Built-in frequency counter
- SO-239 coax fed antenna connector
- Connector for random wire or single wire antennas
- Optional remote control
- Optional radio interface for compatible radios

Specifications

- Impedance matching range: 12 to 800 ohms
- Minimum power for tuning: 10 watts
- Maximum power while tuning: 100 watts with foldback, 20 watts without foldback
- RF power limit: 600 watts PEP SSB/300 watts CW
- Frequency range: 1.8 to 30 MHz continuous coverage
- Frequency counter accuracy: ± 1 kHz across HF bands
- Frequency counter range: up to 50 MHz
- Capacitance range: 0 to 2950 pF (192 values)
- Inductance range: 0 to 17 μ H (192 values)
- Relay rating: 16 amp 1000 volts
- Relay electrical life: 100,000 operations
- Relay mechanical life: 10 million operations
- Memory endurance: 1 million write cycles
- Memory data retention: 100 years
- Power requirements: 12 - 15 volts DC, 2.1 \times 5.5 mm coaxial plug, center pin positive
- Current consumption: 1 amp or less
- Dimensions (approx.): 10.1 \times 2.8 \times 9.2 in. (257 \times 71 \times 234 mm) (width/height/depth)
not including connectors
- Weight (approx.): 3.7 lb (1.68 kg)

† Specifications and design are subject to change without notice.

Fast Start

WARNINGS

- *Never operate the tuner with its cover removed. Contact with the components inside the tuner while transmitting will result in painful RF burns.*
- *Locate the tuner so that the rear terminals are **not accessible** during operation. The single wire connection may have high voltage while transmitting.*
- *Disconnect all antennas from the tuner during lightning storms.*
- *Always tune with low power (about 10 watts). Apply maximum power only after tuning up.*
- *Never exceed tuner specifications.*
- *Do not transmit with a high SWR for extended periods of time.*

1. Connect the tuner to a 12-15 VDC voltage source capable of supplying at least 1 amp.
2. Connect your transmitter to the TRANSMITTER connector using a 50-ohm coaxial cable.
3. Connect your coax-fed antenna to the ANTENNA connector using a 50-ohm coaxial cable, or connect your random wire to the WIRE binding post.
4. Connect your ground connection to the GROUND post.
5. Press the [POWER] button to turn on the tuner. Lock the [AUTO] button in to select semi-automatic mode.
6. Key your transmitter to output a carrier of 10 watts CW, FM or AM.
7. Press and hold the [TUNE] button for one second to start the automatic tuning process. When completed, check to ensure an SWR of 2.0 or less before increasing RF power.
8. You are ready to transmit.

Note: *During the automatic tuning process, the tuner will make some noise. These are the relays switching at a very fast pace and it is normal operation. Do not be alarmed.*

Note: *When the tuner power is OFF, the tuner is in bypass mode and RF from the transmitter goes directly to the antenna with no matching. When the tuner power is ON, pressing [C-DN] and [L-DN] simultaneously or pressing [TUNE] quickly places the tuner in bypass mode (zero inductance and zero capacitance) and indicates by the reflected needle bouncing to 20-watt mark.*

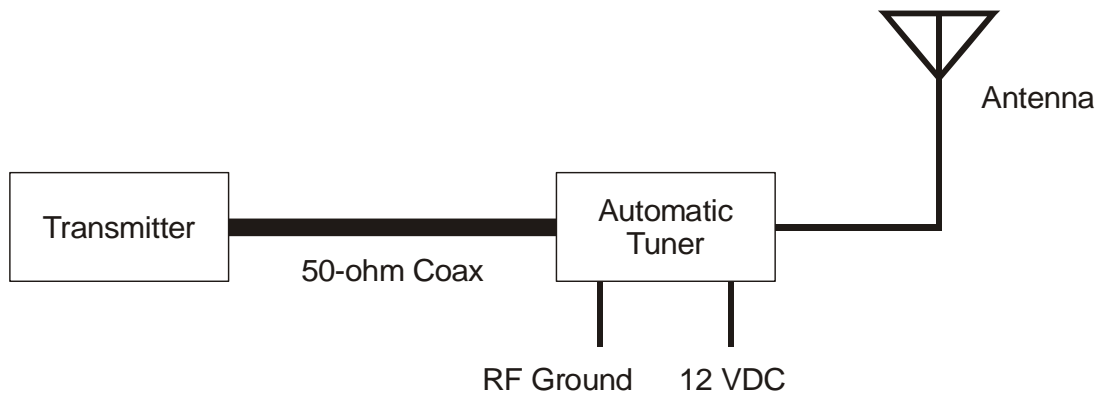

Figure 1. Installation Block Diagram.

Front Panel



Figure 2. MFJ-994 Front Panel.

- SWR/Wattmeter:** The cross-needle meter measures forward power, reflected power, and SWR. It operates whenever the tuner is power on. Full-scale readings are 3000 watts forward and 600 watts reflected. The meter can be set to low power range of 300 watts forward and 60 watts reflected. The SWR is measured at the point where the two needles cross. See “SWR/Wattmeter” on page 8 for more detailed information.
- C-UP and C-DN Buttons:** Used to manually increase or decrease the capacitance of the L-network matching circuit. The capacitance range is 0 to 2950 pF. The upper limit of capacitance, dependent on frequency, is restricted to limit the maximum voltage and current across the tuner’s components.

Note: Pressing [C-UP] and [C-DN] simultaneously toggles the capacitor between the input and output sides of the L-network. Forward needle bounces to 30-watt mark when the capacitor is on the transmitter side. Reflected needle bounces to 5-watt mark when the capacitor is on the antenna side.

- L-UP and L-DN Buttons:** Used to manually increase or decrease the inductance of the L-network matching circuit. The inductance range is 0 to 17 μ H. The upper limit of inductance, dependent on frequency, is restricted to limit the maximum voltage and current across the tuner’s components.

Note: Pressing [C-DN] and [L-DN] (both DOWN buttons) simultaneously places the tuner in bypass mode. The reflected needle bouncing to the 20-watt mark indicates this. RF from the transmitter goes directly to the antenna with no matching.

- AUTO Button:** Used to select automatic or semi-automatic tuning mode. Button *out* selects automatic mode – the tuning routine is automatically started when at least ten watts of power is applied and the SWR is a preset amount above the preset target SWR. Button *in* selects the semi-automatic mode – the tuning routine starts only when the [TUNE] button is pressed.

Note: During the tuning process, the tuner will make some noise. These are the relays switching at a very fast pace and it is normal operation. Do not be alarmed.

- TUNE Button:** Has three different functions based on the length of time you press and hold it before releasing. Press [TUNE] quickly (less than 0.5 second) to bypass the tuner. RF from the transmitter goes directly to the antenna with no matching.

Press and hold [TUNE] for 0.5 to 2 seconds to start the automatic tuning process. The transmitter must be keyed first with at least ten watts of power. When the SWR is already below the target SWR, pressing [TUNE] will fine-tune the match for a lower SWR, if possible.

“*StickyTune*” allows for one-handed tuning operation. Normal tuning requires keying the transmitter with one hand and using the other hand to push the [TUNE] button to start the tuning process. To toggle the *StickyTune* mode on and off, press and hold the [TUNE] button for two seconds. The Reflected Power needle goes to 60-watt mark when on and to 5-watt mark when off. When *StickyTune* is enabled, the tuning process starts automatically when the transmitter is keyed with at least ten watts of power regardless of the SWR. This works in both automatic and semi-automatic modes.

- **POWER Button:** Used to turn the power on and off. Note that during power-on the analog meter bounces four times to indicate the model 994. When the power is off, the tuner is placed in bypass mode (straight through from TRANSMITTER to ANTENNA and WIRE). When power is turned on, the tuner automatically restores all previous settings.

WARNING: Do not turn the power on and off rapidly, otherwise the tuning setting memory can be corrupted and the unit will have to be reset to factory defaults.

BUTTON ACTION

- Press **POWER** in to turn power on, out to turn power off.
- Press **C-UP** to increase capacitance.
- Press **C-DN** to decrease capacitance.
- Press **L-UP** to increase inductance.
- Press **L-DN** to decrease inductance.
- Press **AUTO** in to select semi-automatic mode, out to select automatic mode.
- Press **TUNE** less than 0.5 second to bypass the tuner; press and hold for 0.5 to 2 seconds to start the tuning process; press and hold for more than two seconds to toggle the StickyTune on and off.
- Press **C-UP** + **C-DN** to switch the capacitor between the input and output side.
- Press **C-UP** + **L-UP** to increase both capacitance and inductance.
- Press **C-DN** + **L-DN** to bypass the antenna tuner.
- Press **TUNE** + **C-UP** to toggle the Target SWR between 1.5 and 2.0.
- Press **TUNE** + **L-UP** to cycle the Auto Tune SWR among 0.5, 1.0 and 1.5 above the target SWR.
- Press **TUNE** + **C-DN** to toggle the Auto Range on and off.
- Press **TUNE** + **L-DN** to toggle the Meter Range between 3000 and 300 watts (disable Auto Range).

Figure 3. Button Action.

Back Panel

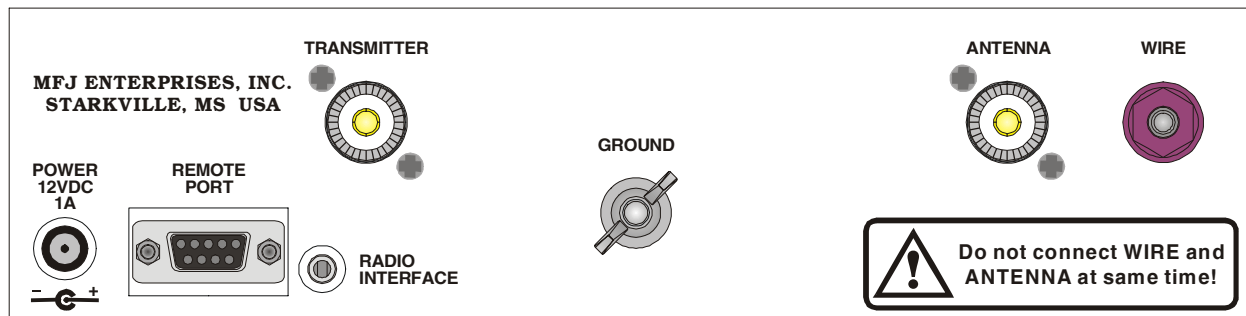

Figure 4. MFJ-994 Back Panel.

- Power:** This jack accepts a standard 2.1 × 5.5 mm coaxial plug with positive center and negative sleeve. The tuner requires 12 volts DC at up to 1 amp. The use of a regulated supply is not mandatory but is recommended for best performance. An optional 12 volts DC 1.5 amp power supply, the MFJ-1316, is available from MFJ Enterprises, Inc.

WARNING: Do not apply voltages greater than 18 volts to this unit, or permanent damage to the unit may result.

Note: When the tuner power is OFF, the tuner is in bypass mode and RF from the transmitter goes directly to the antenna with no matching.

- Remote Port:** A female DB-9 connector for connecting to the MFJ-993RC Remote Control, allowing remote operation of the tuner. The MFJ-993RC duplicates all the front panel buttons except [POWER]. In addition, there are two LEDs on the remote control. The red Tuning LED lights to indicate tuning is in progress and the green SWR LED lights when the SWR is below the target SWR.

Note: To use the remote control, the [AUTO] button on the automatic tuner must be locked in; otherwise, Automatic mode is selected.

- Radio Interface:** A 3.5 mm stereo phone jack for connecting to the tuner interface connector of compatible radios. The tuner should be powered on first (both needles will bounce) and then the radio, so the radio knows a remote tuner is present.

The Radio Interface works with radios that are compatible with the Icom AH-3, Icom AH-4 and Alinco EDX-2 tuners. When connected to a compatible radio, it enables the Tune button on the radio. Pressing the Tune button on the radio causes the radio to temporarily switch to CW mode, transmit 10 watts and start the tuning process. Once the tuning process is completed, the tuner signals the radio and the radio returns to the previous mode and power setting.

WARNING: Make sure the +13.8 volts connection on the radio's tuner port is capable of supplying at least 1 amp of current, since the MFJ-994 use up to 1 amp.

Interface cables for Alinco and Icom radios are available from MFJ Enterprises, Inc. Interface cables for compatible Kenwood and Yaesu radios will be available in the future. The MFJ-5124A interface

cable provides power and control between an Alinco radio and the MFJ automatic tuner. Supported Alinco radios are DX-70, DX-77, and any Alinco radio that supports the Alinco EDX-2 tuner.



- Pin 1 (Ground) connects to the Sleeves of both 3.5 mm Stereo Phone Plug and Power Plug.
- Pin 2 (+13.8V) connects to the Center Pin of Power Plug.
- Pin 3 (Key) connects to the Tip of 3.5 mm Stereo Phone Plug.
- Pin 4 is not connected.
- Pin 5 (Start) connects to the Ring of 3.5 mm Stereo Phone Plug.

Figure 5. Alinco Interface Cable.

The MFJ-5124I interface cable provides power and control between an Icom radio and the MFJ automatic tuner. Supported Icom radios are IC-706, IC-707, IC-718, IC-725, IC-728, IC-736, IC-738, IC-746, IC-756, IC-765, IC-775, and any Icom radio that supports the Icom AH-3 and AH-4 tuners. Push and hold the radio's [TUNER] button for two seconds to start the tuning process. Push [TUNER] quickly to bypass the tuner.



- Pin 1 (Key) connects to the Tip of 3.5 mm Stereo Phone Plug.
- Pin 2 (Start) connects to the Ring of 3.5 mm Stereo Phone Plug.
- Pin 3 (+13.8V) connects to the Center Pin of Power Plug.
- Pin 4 (Ground) connects to the Sleeves of both 3.5 mm Stereo Phone Plug and Power Plug.

Figure 6. Icom Interface Cable.

- **Transmitter:** SO-239 connector for coax cable from transmitter or transceiver.
- **Ground:** Wing-nut terminal for RF ground wire connection.
- **Wire:** Binding post for connecting single wire antenna. Notice the WIRE binding post is internally connected to the ANTENNA connector.

Note: To use the WIRE binding post, make sure to remove the antenna, if any, from the ANTENNA connector.

- **Antenna:** SO-239 connector for coax cable from antenna. Notice the ANTENNA connector is internally connected to the WIRE binding post.

Note: To use the ANTENNA connector, make sure to remove the wire antenna, if any, from the WIRE binding post.

Installation

WARNING

- **Never operate the tuner with its cover removed. Contact with the components inside the tuner while transmitting will result in painful RF burns.**
- **Locate the tuner so that the rear terminals are *not accessible* during operation. The single wire connection may have high voltage while transmitting.**
- **Disconnect all antennas from the tuner during lightning storms.**
- **Always tune with low power (about 10 watts). Apply maximum power only after tuning up.**
- **Never exceed tuner specifications.**
- **Do not transmit with a high SWR for extended periods of time.**

1. Place the tuner in a convenient location at the operating position. With a random wire antenna the feed through insulator can have high RF voltage. This voltage can cause serious RF burns if the terminal is touched when transmitting. **Be sure to locate the tuner so this terminal cannot accidentally be contacted during operation.**
2. Connect the tuner to the transmitter with 50-ohm coaxial cable (such as RG-8/U). See Figure 1 on page 3.
3. Connect the antenna to the tuner as follows:
 - Coaxial feedline to the SO-239 connector labeled ANTENNA; or
 - Random wire or single wire line antennas should be connected to the WIRE binding post on the back of the tuner. Note the back panel warning: **Do not connect WIRE and ANTENNA at same time!**

Note: Route all single and random wire antennas safely to prevent RF burn hazard.

4. A GROUND post is provided for an RF ground connection. See “Grounding Hints” on page 13.
5. Connect a 12 to 15 VDC power source to the input jack labeled POWER.

SWR/Wattmeter

Note: All meter power readings and ranges are $\times 10$.

The backlit cross-needle meter measures forward power, reflected power, and SWR, and operates whenever the tuner is powered on. Forward power up to 3000 watts is displayed on the left-hand FORWARD meter scale. Reflected power up to 600 watts is read on the right-hand REFLECTED meter scale. For low-power tuning, meter ranges of 300 watts forward and 60 watts reflected are available. Multiply the readings on these scales by ten when in the high power meter range.

To toggle between the high and low meter ranges, press the [TUNE] and [L-DN] buttons simultaneously. The forward

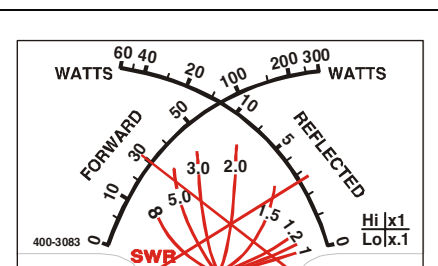

Figure 7. SWR/Wattmeter.

needle will read “300” for high range and “30” for low range until the buttons are released, to indicate the range selected.

The meter can be set to auto range. Auto range automatically sets the meter scales according to the input RF power to the tuner. Forward power greater than 300 watts or reflected power greater than 60 watts automatically sets the meter to the high power range. Forward power less than 250 watts and reflected power less than 40 watts automatically set the meter to the low power range. To toggle auto range on and off, press the [TUNE] and [C-DN] buttons simultaneously. The reflected needle will read “60” for auto range ON and “5” for auto range OFF.

The SWR is read from the eight red SWR curves that range from 1.0 to infinity. The SWR is measured by observing the point where the forward and reflected power needles cross on the red curved scales across the center of the meter. No cumbersome or time-consuming SWR sensitivity adjustments are required with this meter. Figure 7 shows an SWR of approximately 2.0.

$$SWR = \frac{1 + \sqrt{\frac{\text{reflected power}}{\text{forward power}}}}{1 - \sqrt{\frac{\text{reflected power}}{\text{forward power}}}}$$

The meter also indicates various operational states of the tuner. Refer to “Tuner Status Indicators” on page 12 for more details.

Setup

You can set up how the MFJ-994 tuner works and behaves. In addition to displaying power and SWR, the meter also indicates tuner status when you make setup changes. The meter needles bounce, or rise to one point and stay, to provide information. In this mode the meters do *not* indicate power levels. For example, when you press [C-DN] and [L-DN] simultaneously to place the tuner in bypass mode, the reflected needle bounces to the 20-watt mark until you release the buttons. Table 2 summarizes the meter needle stationary and bounce codes.

Target SWR

You can set the target SWR to 1.5 or 2.0. The tuning process will stop when a match with an SWR less than or equal to the target SWR is found. The default is 1.5. Setting the target SWR to 2.0 may require shorter tuning times. You can toggle the target SWR between 1.5 and 2.0 by pressing [TUNE] and [C-UP] simultaneously; the meter needles intersect at SWR of 1.5 or 2.0 to indicate the change.

Auto Tune SWR

You can set the SWR threshold to 0.5, 1.0 or 1.5. In the automatic mode, the tuning process will automatically start when the SWR is above the target SWR by this amount of SWR threshold. For example, for target SWR of 1.5 and auto tune SWR of 1.0, the tuning process will start whenever the SWR is above 2.5 (1.5 + 1.0) and there is at least ten watts of RF power. Default is 1.0. Press [TUNE] and [L-UP] simultaneously to cycle the auto tune SWR among 0.5, 1.0 and 1.5 (Reflected Power meter needle reads 5, 20 and 60 watts, respectively).

Meter Range

Note: All meter power readings and ranges are $\times 10$.

You can select a meter scale range or use auto range. In the 300 watts (low) range, the forward full scale is 300 watts and the reflected full scale is 60 watts. In the 3000 watts (high) range, the forward full scale is 3000 watts and the reflected full scale is 600 watts (multiply the meter reading by 10). Auto range automatically sets the meter scales according to the input RF power to the tuner. Forward power greater than 300 watts or reflected power greater than 60 watts automatically sets the meter to the high power range. Forward power less than 250 watts and reflected power less than 40 watts automatically set the meter to the low power range. Default is 3000 watts range.

Press [TUNE] and [C-DN] simultaneously to toggle Auto Range on and off. Press [TUNE] and [L-DN] simultaneously to toggle between 3000 and 300 watts meter range and disable Auto Range.

Operation

Manual Tuning

In certain cases the operator may wish to “touch up” the tuner’s settings. For example, if the target SWR is set at the default of 1.5, the tuner will stop when a match of 1.5 is found. In all cases, manual tuning gives the user control of the tuner if desired. Manual tuning is accomplished by using the [C-UP], [C-DN], [L-UP], and [L-DN] buttons. Since it is not known if more or less capacitance (or inductance) is needed, manual tuning must be by trial-and-error. Press [C-UP] one time, and the reflected power will indicate if [C-UP] was the right “direction.” If it was, press [C-UP] again and observe reflected power. If not, press [C-DN] twice (once to return to the original setting of C, and once for one click past it).

Manual tuning of inductance is similarly accomplished, using [L-UP] and [L-DN]. Since the capacitance and inductance are interdependent, some back-and-forth between the two may be needed, just as in a conventional tuner with knobs. Once you are familiar with this process, you will learn how to match certain antennas and frequencies.

Pressing [C-UP] and [C-DN] buttons simultaneously moves the capacitance back and forth from one side of the inductance to the other. Factory default is with the capacitance on the transmitter side. To move the capacitance to the opposite (antenna) side, press [C-UP] and [C-DN] simultaneously. The reflected needle will bounce to 5-watt mark. Press [C-UP] and [C-DN] simultaneously again to return the capacitance to the transmitter side (and the forward needle will bounce to 30-watt mark to indicate the change). A general rule of thumb is that loads with impedance higher than 50 ohms call for the capacitance on the antenna side; loads lower than 50 ohms call for the capacitance on the transmitter side.

Pressing [C-DN] and [L-DN] simultaneously or pressing [TUNE] quickly places the tuner in bypass mode; i.e. zero inductance and zero capacitance. RF from the transmitter goes directly to the antenna with no matching. The reflected needle bouncing to 20-watt mark indicates changing to bypass mode.

Component Limit

The upper limits of inductance (L) and capacitance (C) are factory-limited according to frequency and maximum power rating; i.e., higher frequencies need less inductance and less capacitance when the L-network is properly tuned. Pressing [C-UP] and/or [L-UP] allows capacitance and inductance to be increased only to these limits. When a selected capacitance or inductance is higher than its allowed limit, and the frequency is changed, that selection is automatically reduced to the value of its limit. These limits are used to prevent matching of extreme load impedance outside the tuner's specification, which may result in excess voltage and/or current across the tuner's components.

Antenna Memory

The "memory resolution" is the width of frequency spectrum that the tuner recognizes as being the same as a tuned frequency already in memory. The memory resolution is approximately 0.1 percent of the lower frequency of each amateur band. For example, the memory resolution on the 40-meter band (7000 to 7300 kHz) is 7 kHz; if the tuner has memorized a setting for 7050 kHz, it will automatically call up this setting for any frequency from 7047 to 7053 kHz. The memory resolutions for the HF amateur bands 160 through 10 meters are:

Meter	Frequency Range (kHz)	Memory Resolution (kHz)
160	1800 – 2000	2
75/80	3500 – 4000	4
60	5330.5, 5346.5, 5366.5; 5371.5 and 5403.5	two memory locations
40	7000 – 7300	7
30	10100 – 10150	10
20	14000 – 14350	14
17	18068 – 18168	18
15	21000 – 21450	21
12	24890 – 24990	25
10	28000 – 29700	28

Table 1. Antenna Memory Resolution.

The memory resolution for non-amateur frequency bands between 160 and 10 meters is approximately one percent of the lower frequency of that band. There are more than one thousand antenna memory locations.

To clear the antenna memory, turn off the power to the tuner, then press and hold both [TUNE] and [C-DN] buttons while turning on the power. Both meter needles will read half scale, forming a triangle, asking you to confirm the deletion. Press [C-UP] to confirm delete (both meter needles will read full scale), or press [L-UP] to cancel the antenna memory delete (both meter needles will read zero).

"Total Reset" erases the antenna memory *and* returns all tuner settings to their factory default states. To achieve this, turn power off, press and hold [TUNE], [L-DN] and [C-DN] buttons while turning on the power. The meter needle readings will be the same as for antenna memory delete: half scale. Press [C-UP] to confirm total reset (needles go to full scale) or press [L-UP] to cancel total reset (needles go to zero).

Tuner Status Indicators

If not enough power is applied for tuning (less than 10 watts), the Forward Power needle will bounce to the 100-watt mark. When input power is too high, the tuner enters a self-protection mode and the Forward Power meter needle bounces to 300-watt mark (full scale). The tuner will not allow any of its relays to change. This feature is to prevent damage to your tuner.

If too much power is applied when tuning is in progress, the tuner will cease the tuning routine, and the Forward Power meter needle will bounce to full scale. This occurs when the forward power exceeds 75 watts and the SWR is greater than 3.0, or when the forward power exceeds 125 watts regardless of the SWR. If more than 600 watts is applied to the tuner, the tuner will go into bypass mode; both Forward and Reflected meter needles will bounce to full scale.

Default	Tuner Status	Button Action	Meter Needles
			Stationary Needle Reads
	Meter Range 300 watts	[TUNE] + [L-DN]	30-watt Forward
*	Meter Range 3000 watts	[TUNE] + [L-DN]	300-watt Forward
*	Auto Range OFF	[TUNE] + [C-DN]	5-watt Reflected
*	Sticky Tune OFF	[TUNE] 2 seconds	
	Auto Tune SWR +0.5	[TUNE] + [L-UP]	
*	Auto Tune SWR +1.0	[TUNE] + [L-UP]	20-watt Reflected
	Auto Range ON	[TUNE] + [C-DN]	60-watt Reflected
	Sticky Tune ON	[TUNE] 2 seconds	
	Auto Tune SWR +1.5	[TUNE] + [L-UP]	
			Both Needles – Stationary
	NO, do not delete	[L-UP]	0 scale
	Confirm Delete	N/A	Mid-scale
	YES, delete	[C-UP]	Full scale
*	Target SWR 1.5	[TUNE] + [C-UP]	Needles intersect at SWR 1.5
	Target SWR 2.0	[TUNE] + [C-UP]	Needles intersect at SWR 2.0
			Bouncing Needle Reads
*	Capacitor on Transmitter side	[C-UP] + [C-DN]	30-watt Forward
	Insufficient power to tune (Forward < 10 watts)	[TUNE]	100-watt Forward
	Too much power to tune (Forward > 75 watts and SWR > 3) or (Forward > 125 watts)	N/A	300-watt Forward
	Capacitor on Antenna side	[C-UP] + [C-DN]	5-watt Reflected
*	Bypass Mode (L = 0 and C = 0)	[C-DN] + [L-DN] or [TUNE] < 0.5 second	20-watt Reflected
	L or C at its limit during manual adjustment	[C-UP], [C-DN], [L-UP] or [L-DN]	60-watt Reflected
			Both Needles – Bouncing
	Input Power Overload (Forward > 600 watts)	N/A	Full scale

Table 2. Meter Needle Codes.

Grounding Hints

To minimize RFI, single wire feedlines (such as used with Windom or longwire antennas) should be kept away from other wiring. Radiation will be minimized if the single wire feeder runs parallel and reasonably close to the wire that connects the tuner to the outdoor ground. The antenna feed wire should be adequately insulated to prevent arcing or accidental contact.

CAUTION

For operator safety, a good outside earth ground or water pipe ground should always be installed and connected to the case of the antenna tuner. Make certain the safety ground also connects to the transmitter and other station accessories. A wing-nut post marked GROUND is provided for ground connections.

For safety, please use good DC and RF grounds. It is particularly important to have a good RF ground when using a single wire feeder. When using a single wire feeder, the tuner needs something to "push" against in order to force current into the single wire feedline. If a good RF ground is not available, RF will usually find its way back into the power line (RFI), transmitter audio circuits (RF feedback), or the operator (RF burns).

Metal water pipes and ground rods provide good DC and AC safety grounds, but they are often inadequate for RF grounding because they are single conductors. Ground rods by themselves are almost useless for dependable RF grounding.

RF grounds work much better when "spread out" over a large area, especially when they employ multiple connections directly to the equipment ground point. Metal water pipes, heating ducts, and fences may work (especially if they are connected together with multiple wires), but the best RF grounds are radial systems or multi-wire counterpoises. Radials and counterpoises provide large, low resistance surfaces for RF energy.

RF and lightning travel on the surface of conductors. Braided or woven conductors have high surface resistance to lightning and RF. Ground leads for RF and lightning should have wide smooth surfaces. Avoid the use of woven or braided conductors in RF and lightning grounds unless the lead needs to be flexible.

Antenna System Hints

Location

For the best performance, an end-fed longwire wire antenna should be at least one quarter-wavelength long at the operating frequency. Horizontal dipole antennas should be at least a half-wavelength long and located as high and clear as possible. While good RF grounds help the signal in almost any transmitting installation, it is extremely important to have good RF grounds with long wire or other Marconi-style antennas.

Matching Problems

Most matching problems occur when the antenna system presents an extremely high impedance to the tuner. When the antenna impedance is much lower than the feedline impedance, an *odd quarter-*

wavelength feedline converts the low antenna impedance to a very high impedance at the tuner. A similar problem occurs if the antenna has an extremely high impedance and the transmission line is a multiple of a half-wavelength. The half-wavelength line *repeats* the very high antenna impedance at the tuner. Incorrect feedline and antenna lengths can make an otherwise perfect antenna system very difficult or impossible to tune.

One example where this problem occurs is on 80 meters when an odd quarter-wave (60 to 70 feet) open wire line is used to feed a half-wave (100 to 140 feet) dipole. The odd quarter-wave line transforms the dipole's low impedance to over three thousand ohms at the tuner. This is because the mismatched feedline is an *odd multiple* of 1/4 wavelength long. The line *inverts* (or teeter-totters) the antenna impedance.

A problem also occurs on 40 meters with this same antenna example. The feedline is now a multiple of a half-wave (60 to 70 feet) and connects to a full-wave high impedance antenna (100 to 140 feet). The half-wave line repeats the high antenna impedance at the tuner. The antenna system looks like several thousand ohms at the tuner on 40 meters.

This places enormous strain on the balun and the insulation in the tuner, since voltages can reach several thousand volts. This can cause component arcing and heating.

The following suggestions will reduce the difficulty in matching an antenna with a tuner:

- Never center feed a half-wave multi-band antenna with a high impedance feedline that is close to an odd multiple of a quarter-wave long.
- Never center feed a full-wave antenna with a feedline close to a multiple of a half-wave long.
- If this tuner will not "tune" a multi-band antenna, add or subtract 1/8 wave of feedline (for the band that won't tune) and try again.
- Never try to load a G5RV or center fed dipole on a band below the half-wave design frequency. If you want to operate an 80-meter antenna on 160 meters, feed either or both conductors as a longwire against the station ground.

To avoid problems matching or feeding any dipole antenna with high impedance open wire lines, keep the lines around these lengths. [The *worst possible* line lengths are shown in brackets]:

160 meters dipole:	35-60, 170-195 or 210-235 feet	[Avoid 130, 260 ft]
80 meters dipole:	34-40, 90-102 or 160-172 feet	[Avoid 66, 135, 190 ft]
40 meters dipole:	42-52, 73-83, 112-123 or 145-155 feet	[Avoid 32, 64, 96, 128 ft]

Some slight trimming or adding of feedline may be necessary to accommodate the higher bands.

WARNING

To avoid problems, a dipole antenna should be a full half-wave on the lowest band. On 160 meters, an 80 or 40 meter antenna fed the normal way will be extremely reactive, with only a few ohms of feedpoint resistance. Trying to load an 80 meter half-wave dipole (or shorter) antenna on 160 meters can be a disaster for both your signal and the tuner. The best way to operate 160 meters with an 80 or 40 meters antenna is to load either or both feedline wires (in parallel) as a longwire. The antenna will act like a "T" antenna worked against station ground.

Appendices

POWER-ON OPERATIONS			
(Press and hold buttons while turning on the power.)			
Press and hold	C-UP	+	POWER to get the firmware version number.
Press and hold	L-UP	+	POWER to start the self test.
Press and hold	C-DN	+	POWER to test the relays.
Press and hold	L-DN	+	POWER to test the power-down circuitry.
Press and hold	TUNE + C-UP	+	POWER to calibrate the wattmeter.
Press and hold	TUNE + L-UP	+	POWER to calibrate the SWR bridge.
Press and hold	TUNE + C-DN	+	POWER to delete the antenna memory.
Press and hold	TUNE + L-DN	+	POWER to reset factory defaults.
Press and hold	TUNE + C-DN + L-DN	+	POWER to perform total reset.
Press and hold	C-UP + L-UP	+	POWER to calibrate the frequency counter.

Figure 8. Power-On Operations.

Important: *The radio interface cable must be disconnected from the tuner, if the radio power is off, before performing any of the following power-on operations.*

Firmware Version Number

Make sure the meter is calibrated. To obtain the firmware version number, press and hold the [C-UP] button while turning the power on. The version number X.XY is represented by the meter forward needle for X.X and the reflected needle for Y. For example, forward needle on 10-watt mark and reflected needle on 2-watt mark represent firmware version number 1.02. Release button to resume normal operation.

Resetting the Tuner

Each time the tuner is powered off, the microprocessor saves all memories and configurations to non-volatile memory ready to be used the next time the unit is turned on again. If the tuner is not working properly, even on initial power on, try resetting to the factory defaults.

Factory Defaults

The unit is shipped with the following default settings:

- Inductance 0 μ H
- Capacitance 0 pF on transmitter side
- Target SWR 1.5

- Auto Tune SWR 1.0 above target SWR
- Meter Range 3000 watts (high range)

Note: *Resetting to factory defaults does not erase the antenna memory.*

To reset the tuner to these defaults:

1. Turn off the power to the tuner.
2. Press and hold *both* the [TUNE] and [L-DN] buttons while turning the power on.
3. Release the buttons when both meter needles read full scale.
4. Resume with normal operation.

WARNING: **If the tuner is behaving weirdly or acting erratic, try resetting the tuner to factory defaults.**

Delete Antenna Memory

To delete the antenna memory, turn off power to the tuner, and then press and hold *both* the [TUNE] and [C-DN] buttons while turning the power back on. Both meter needles will read half scale. Press the [C-UP] button to delete the antenna memory (both meter needles go to full scale), or press the [L-UP] button to cancel (both meter needles go to zero scale). Release the button to resume normal operation. Remember that the antenna memory will be lost!

Total Reset

To erase the antenna memory and reset to factory defaults, press and hold down the [TUNE], [C-DN] and [L-DN] buttons while turning the power on. Follow the confirmation procedures for “Delete Antenna Memory” above. Remember that all antenna memories will be lost and tuner setting will return to default!

Self Test

A self-test routine checks the functions of the tuner. This routine checks the meter, the front-panel buttons, and the internal memory. During the self-test, you may stop the test by turning off the unit; however, this should NOT be done during the memory test or the memory could be corrupted. The self-test can be completed in approximately 30 seconds.

This test also can be used to test the MFJ-993RC Remote Control. Make sure to lock in the [AUTO] button on the tuner before starting the self-test, and press the buttons on the MFJ-993RC instead of the front-panel buttons when prompted.

Note: *Performing the self-test will reset the unit to its factory default settings.*

Here is the self-test procedure:

1. Turn off the power to the tuner, and press all buttons to the *out* position.
2. Unplug the radio interface cable, if one is connected, from the tuner.
3. If testing the MFJ-993RC Remote Control, connect it to the Remote Port and make sure the [AUTO] button *on the tuner* is locked in; otherwise, go to next step.
4. Press and hold *only* the [L-UP] button while turning the power on.

5. The test begins by the forward needle of the meter going up slowly to full scale and then drops to zero, followed by the reflected needle going up slowly to full scale and then dropping to zero. This tests the meter. Release the [L-UP] button before the reflected needle goes to zero.
6. The reflected needle goes to the 3-watt mark. Now, press each of the front panel buttons in this sequence: [C-UP], [C-DN], [L-UP], [L-DN], [AUTO], and then [TUNE]. The forward needle should bounce once for each press, and the reflected needle should move up a division for each press.
7. The unit then tests its non-volatile memory. This will reset the unit to its factory default settings.
8. If the unit is okay, both meter needles will go to full scale. If there is a problem, the forward needle will bounce and the reflected needle mark will indicate the failure.
9. Turn the tuner power off.

Failure Message	Reflected Needle (watts)	Indicates
C-UP FAIL	3	[C-UP] button is shorted or improperly connected.
C-DN FAIL	4	[C-DN] button is shorted or improperly connected.
L-UP FAIL	5	[L-UP] button is shorted or improperly connected.
L-DN FAIL	7.5	[L-DN] button is shorted or improperly connected.
AUTO FAIL	10	[AUTO] button is shorted or improperly connected.
TUNE FAIL	15	[TUNE] button is shorted or improperly connected. Radio interface cable is connected but radio power is off.
MEMORY FAIL	20	Non-volatile memory circuitry is improperly connected.
WAKEUP FAIL	30	Microprocessor wakeup circuitry problem.
PD FAIL	40	Power down circuitry problem.

Table 3. Failure Messages.

Power-Down Circuit Test

When the 12 VDC power to the tuner is turned off, the tuner saves all settings to non-volatile memory. The Power-Down Circuit Test checks the power down detection circuitry. It is recommended that this test be done immediately after the regular self-test described above.

Note: *The tuner must be reset to factory defaults before performing this test.*

Here is the test procedure:

1. Make sure power to the tuner is off.
2. If the tuner has been reset to factory defaults, skip to step 6; otherwise continue with step 3.
3. Press and hold *both* the [TUNE] and [L-DN] buttons while turning the power on.
4. Release both buttons when both meter needles read full scale.
5. Turn the power off.
6. Press and hold *only* the [L-DN] button while turning the power on.
7. If the power down detection circuitry is okay, both meter needles will go to full scale. If there is a problem, the forward needle will bounce and the reflected needle will read 40, per Table 3 above.
8. Turn the power off.

Relay Test

WARNING: Turn off the transmitter power or disconnect the transmitter before performing this test; otherwise, damage to the tuner can result.

To test the relays and their control circuitry, press and hold the [C-DN] button while turning the power on. Both meter needles will bounce. Release the button. The relays are tested in groups of four as shown in the table below. The [C-UP], [L-UP], [C-DN] and [L-DN] buttons are used to toggle each relay in each group of four. Press button to engage the relay and release it to disengage the relay. Listen for relay clicks. Press the [TUNE] button to proceed to the next group of four relays. There are 18 relays in the tuner. Repeat the above procedure to test all the relays. Normal operation is resumed after this test. The reflected power needle indicates which group of relays is being checked as follows:

Reflected Needle	[C-UP]	[L-UP]	[C-DN]	[L-DN]
1-watt mark	1	Not used	3	4
2-watt mark	5	6	7	8
3-watt mark	9	10	11	12
4-watt mark	13	14	15	16
5-watt mark	17	18	19	Not used

Since there are no relays #2 and #20, pressing the [L-UP] button in the first group and the last button [L-DN] in the last group will not produce a click.

Wattmeter Calibration

To calibrate the wattmeter, you will need a Phillips screwdriver and a tuning tool or small flat blade screwdriver.

WARNING: Never operate the MFJ-994 with its cover removed; dangerous voltages and currents can be present during operation. Never exceed tuner specifications.

Note: The trimmers involved in this calibration are located on the circuit board behind the front panel; do not confuse these with the SWR bridge trimmers.

1. Turn off the power to the tuner and the transmitter.
2. Remove the cover from the tuner (12 screws) with a Phillips screwdriver.
3. Press and hold *both* the [TUNE] and [C-UP] buttons while turning the power on. Both meter needles will bounce. Release the buttons.
4. The forward needle will go up. Use a small flat blade screwdriver and adjust the FWD trimpot R75, located behind the display, to set the forward power needle to the 100-watt mark.
5. Press [TUNE] to calibrate the reflected power needle. The forward needle will drop to zero and the reflected needle will go up.
6. Adjust the REF trimpot R76, located behind the display, to set the reflected power needle to the 20-watt mark.
7. Press [TUNE] to resume normal operation.
8. Turn off the tuner power and secure the cover back onto the tuner.

SWR Bridge Calibration

To calibrate the SWR Bridge, you will need a transmitter capable of 100 watts output, a precise calibrated wattmeter, a 50-ohm dummy load, three 50-ohm SO-239 coax cables, a Phillip screwdriver, and a tuning tool or small flat blade screwdriver. Make sure the tuner's meter is calibrated.

WARNING: Do not touch anything inside the tuner during operation! Serious, painful RF burns can result.

WARNING: Never operate the MFJ-994 with its cover removed; dangerous voltages and currents can be present during operation. Never exceed tuner specifications.

Note: *The trimmers involved in this calibration are located on the main circuit board in front of the TRANSMITTER connector; do not confuse these with the SWR/wattmeter trimmers.*

1. Turn off the power to the tuner and the transmitter.
2. Remove the cover from the tuner (12 screws) with a Phillips screwdriver.
3. Connect the 50-ohm dummy load to the ANTENNA connector; connect the wattmeter between the transmitter and the TRANSMITTER connector on the tuner.
4. Turn on the power to the transmitter. Select a frequency in the middle of an HF band, such as 7.253 MHz, for calibration.
5. Press and hold *both* the [TUNE] and [L-UP] buttons while turning the tuner power on. Both meter needles will bounce. Release the buttons.
6. Key the transmitter to output 100 watts and adjust the trimmer capacitor C91 for minimum reflected power. Notice the reflected meter movement is exaggerated for easier calibration.
7. Key the transmitter to 100 watts output and adjust the FWD trimpot R72 until the forward power needle indicates 100-watt mark.
8. Press the [TUNE] button and observe that the reflected power needle goes to full scale.
9. Turn off the transmitter and reverse the ANTENNA and TRANSMITTER connections; that is, connect the 50-ohm dummy load to the TRANSMITTER connector and connect the transmitter/wattmeter to the ANTENNA connector.
10. Turn on the transmitter's power.
11. Key the transmitter to 100 watts output and adjust the REF trimpot R71 until the forward power needle (yes, the forward needle) indicates 100-watt mark; the reflected meter should be at full scale.
12. Press the [TUNE] button to end calibration.
13. Turn off the power to the tuner and the transmitter.
14. Remove the transmitter/wattmeter and the 50-ohm dummy load from the tuner.
15. Secure the cover back onto the tuner.
16. Connect your transmitter to the TRANSMITTER connector and connect your antenna to the appropriate antenna connector on the tuner.

Frequency Counter Calibration

To calibrate the frequency counter, you will need a transmitter, a 50-ohm dummy load, two 50-ohm SO-239 coax cables, a Phillips screwdriver, and a tuning tool or small flat blade screwdriver.

WARNING: Do not touch anything inside the tuner during operation! Serious, painful RF burns can result.

WARNING: Never operate the MFJ-994 with its cover removed; dangerous voltages and currents can be present during operation. Never exceed tuner specifications.

1. Turn off the power to the tuner and the transmitter.
2. Remove the cover from the tuner (12 screws) with a Phillips screwdriver.
3. Connect the 50-ohm dummy load to the ANTENNA connector; connect the transmitter to the TRANSMITTER connector on the tuner.
4. Turn on the power to the transmitter. Set and lock the transmitter frequency to *exactly* 29.000 MHz.
5. Press and hold *both* the [C-UP] and [L-UP] buttons while turning the tuner power on. Both meter needles will go to full scale.
6. Key the transmitter to output about 10 watts. Adjust trimmer capacitor C118 (located between the two big integrated circuits) until the tuner's meter needles settle at the 0-watt marks. Notice the meter movement is exaggerated for easier calibration. Nominal tolerance of the frequency counter is ± 1 kHz.
7. Turn off the power to the tuner and the transmitter.
8. Secure the cover back onto the tuner.

In Case of Difficulty

If the tuner acts erratic, reset the tuner to factory defaults by pressing both the [TUNE] and [L-DN] buttons while turning the power on. If the tuner fails to tune, please **double check** all connections and follow the tuning procedures again. Be sure you are using *enough inductance* (through manual adjustment) and *minimum capacitance*.

If the tuner arcs at the rated power levels, please **double check** all connections and follow the tuning procedures again. Ensure you are not exceeding the tuner's rated power handling capability. If you have adjusted the tuner manually, be sure you are using the *least amount of inductance* and the *greatest capacitance* possible that still allows matching the load on the operating frequency.

Note: *If the tuner arcs when operating on the 160-meter band, it may be necessary to reduce transmitter output power.*

If you are still unsuccessful, but the tuner does adjust and operate when used with a dummy load or another antenna, please read "Grounding Hints" and "Antenna System Hints" on page 13.

Technical Assistance

If you have any problem with this unit first check the appropriate section of this manual. If the manual does not reference your problem or your problem is not solved by reading the manual, you may call *MFJ Technical Service* at 662-323-0549 or the *MFJ Factory* at 662-323-5869. You will be best helped if you have your unit, manual and all information on your station handy so you can answer any questions the technicians may ask.

You can also send questions by mail to MFJ Enterprises, Inc., 300 Industrial Park Road, Starkville, MS 39759; by facsimile (FAX) to 662-323-6551; or by email to techinfo@mfjenterprises.com. Send a complete description of your problem, an explanation of exactly how you are using your unit, and a complete description of your station.

List of Accessories

- **MFJ-993RC**: Remote control
- **MFJ-1316**: 12 VDC 1.5 amp power supply
- **MFJ-5124A**: Interface cable for compatible Alinco radios
- **MFJ-5124I**: Interface cable for compatible Icom radios
- **MFJ-5409**: 6 feet long RS-232 cable, female DB-9 to male DB9 connector
- **MFJ-5803**: 3 feet long RG-58 A/U 50-ohm coax cable with a PL-259 connector on each end
- **MFJ-5806**: 6 feet long RG-58 A/U 50-ohm coax cable with a PL-259 connector on each end
- **MFJ-5818**: 18 feet long RG-58 A/U 50-ohm coax cable with a PL-259 connector on each end

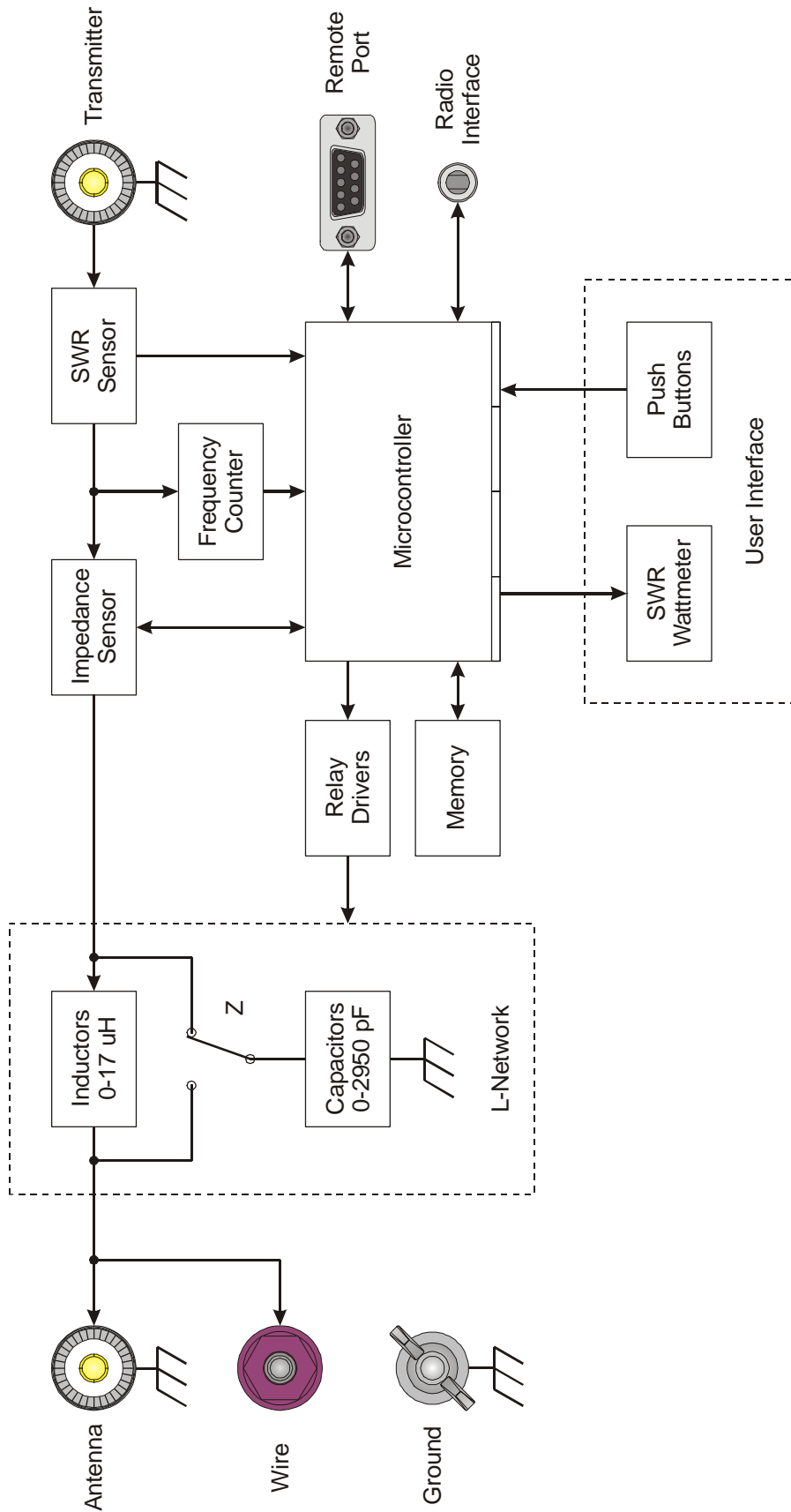

Figure 9. MFJ-994 Circuit Block Diagram.

LIMITED 12 MONTH WARRANTY

MFJ Enterprises, Inc. warrants to the original owner of this product, if manufactured by MFJ Enterprises, Inc. and purchased from an authorized dealer or directly from MFJ Enterprises, Inc. to be free from defects in material and workmanship for a period of 12 months from date of purchase provided the following terms of this warranty are satisfied.

1. The purchaser must retain the dated proof-of-purchase (bill of sale, canceled check, credit card or money order receipt, etc.) describing the product to establish the validity of the warranty claim and submit the original or machine reproduction of such proof of purchase to MFJ Enterprises, Inc. at the time of warranty service. MFJ Enterprises, Inc. shall have the discretion to deny warranty without dated proof-of-purchase. Any evidence of alteration, erasure, or forgery shall be cause to void any and all warranty terms immediately.
2. MFJ Enterprises, Inc. agrees to repair or replace at MFJ's option without charge to the original owner any defective product under warrantee provided the product is returned postage prepaid to MFJ Enterprises, Inc. with a personal check, cashiers check, or money order for **\$7.00** covering postage and handling.
3. This warranty is **NOT** void for owners who attempt to repair defective units. Technical consultation is available by calling the Service Department at 662-323-0549 or the MFJ Factory at 662-323-5869.
4. This warranty does not apply to kits sold by or manufactured by MFJ Enterprises, Inc.
5. Wired and tested PC board products are covered by this warranty provided **only the wired and tested PC board product is returned**. Wired and tested PC boards installed in the owner's cabinet or connected to switches, jacks, or cables, etc. sent to MFJ Enterprises, Inc. will be returned at the owner's expense unrepaired.
6. Under no circumstances is MFJ Enterprises, Inc. liable for consequential damages to person or property by the use of any MFJ products.
7. **Out-of-Warranty Service:** MFJ Enterprises, Inc. will repair any out-of-warranty product provided the unit is shipped prepaid. All repaired units will be shipped COD to the owner. Repair charges will be added to the COD fee unless other arrangements are made.
8. This warranty is given in lieu of any other warranty expressed or implied.
9. MFJ Enterprises, Inc. reserves the right to make changes or improvements in design or manufacture without incurring any obligation to install such changes upon any of the products previously manufactured.
10. All MFJ products to be serviced in-warranty or out-of-warranty should be addressed to:

**MFJ Enterprises, Inc.,
300 Industrial Park Road
Starkville, Mississippi 39759 USA**

and must be accompanied by a letter describing the problem in detail along with a copy of your dated proof-of-purchase.

11. This warranty gives you specific rights, and you may also have other rights which vary from state to state.



MFJ ENTERPRISES, INC.
300 Industrial Park Road
Starkville, MS 39759

MFJ-994 Manual
Version 1B
Printed In U.S.A. 03/2004